

Product Presentation



Application

This test instrument is mainly used to test the dynamic strength of wheeled ride-on toys.

Can simulate driven toys vertically hit the inelastic step in a steady speed of $2\text{m/s} \pm 0.2\text{/s}$, then observe the damaged condition. Applied to toy bicycles, scooters, roller-skate and etc.



Standards

EN71-1 section 8.22 ; ASTM F963 section 8.20
 ISO 8124-1 section 5.24.4 and 5.27 ; GB 6675 section 5.24.4

Key Specification

Model	GT-M19
Control method	PLC touch screen control
Drive mode	Motor drive
Test speed	2m/s
Non-resilient step height	50mm
Weights protection frame material	Aluminum profile
Dimensions	470x120x210cm
Equipment weight	555kg

Accessories

Standards accessories	1set	GT-MA19 Load A and Load B
Optional accessories	Optional	GT-MA16 Loads for stability test: for ISO 8142-1 section 5.24.4 and GB 6675 section 5.24.4
	Optional	GT-MA21 Static strength test load for ASTM F963 section 8.20
	Optional	GT-MA20 Test platform block for EN71-1 section 8.22.3.3 and ISO 8124-1 section 5.27.3
	Optional	GT-MB01 Sharp Edge Tester
	Optional	GT-MB04 Sharp Point Tester

Specification (for Dynamic Strength Test Loads)

Part	Mass kg (lbs)	Diameter mm (in)	Height mm (in)
a	10.42 (23.0)	150±2 (5.9±0.1)	75±2 (3.0±0.1)
b	14.58 (32.1)	178±2 (7.0±0.1)	75±2 (3.0±0.1)
c	4.16 (9.2)		
d	2.00±0.02 (4.4±0.04)		
e	0.50±0.01 (1.1±0.02)		

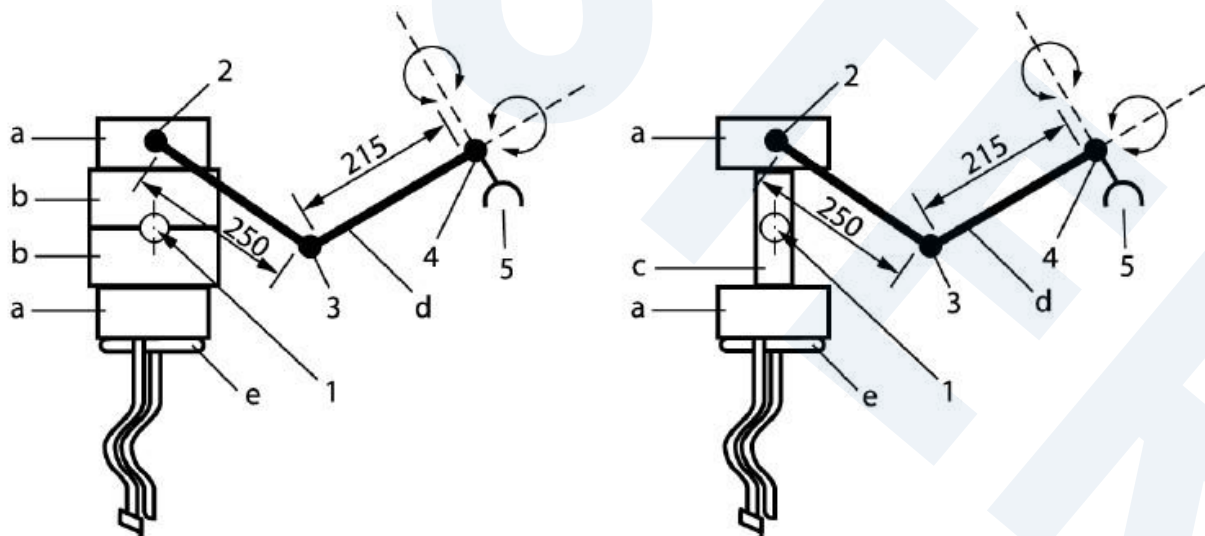

a) Load A for toys intended for children of 36 months and over

b) Load B for toys labelled as not suitable for children of 36 months or over